

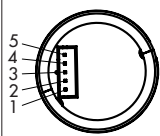

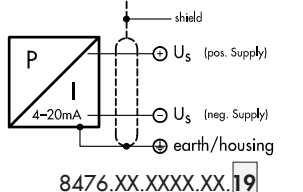

Elektrischer Anschluss / Raccordement électrique / Electrical connection

Schutzart/ protection Ausführung Exécution Execution Ausgangssignal Signal de sortie Output	IP20 JST B5B-PH 36 
 <p>shield \ominus U_s (pos. Supply) \ominus U_s (neg. Supply) \oplus earth/housing 8476.XX.XXXX.XX.19</p>	5 1 
 <p>shield for DC supply \ominus output \ominus common \ominus 8476.XX.XXXX.XX.14/23</p>	5 3 1 

Anziehdrehmoment Druckanschluss / Couple de serrage raccord de pression / Torque moment pressure connection

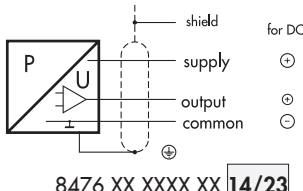
15...20Nm

Betriebstemperatur / Température de service / Operating temperature

-25°C ... +85°C

Lagertemperatur / Température de stockage / Storage temperature

-25°C ... +85°C

Medientemperatur / Température du fluide / Media temperature

-25°C ... +125°C

O-Ring (medienberührend) / Joint torique (contact. de médias) / O-Ring (media contacting)

EPDM ...XX.63

