

Massbilder / Cotes d'encombrement / Dimensions

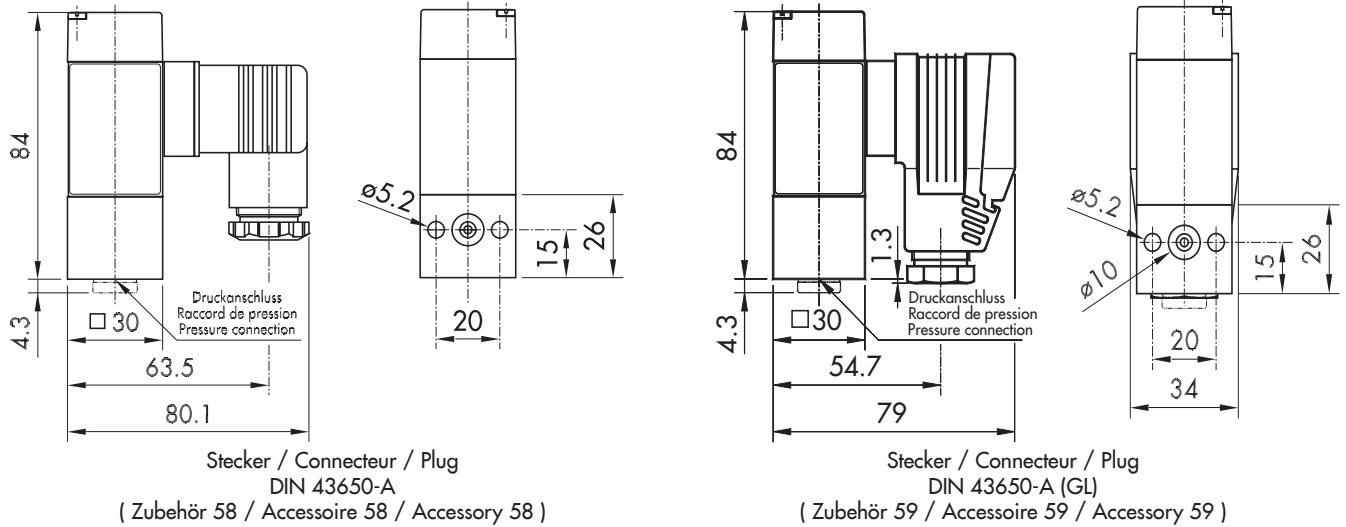



Stecker / Connecteur / Plug  
DIN 43650-A

(Zubehör 58 / Accessoire 58 / Accessory 58)

Stecker / Connecteur / Plug  
DIN 43650-A (GL)

(Zubehör 59 / Accessoire 59 / Accessory 59)

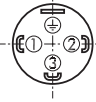
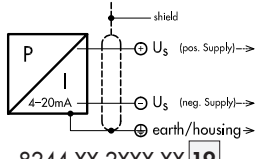
Elektrischer Anschluss / Raccordement électrique / Electrical connection

Schutzart/ Protection <sup>2)</sup>	IP65 <sup>2)</sup>
Ausführung Exécution Execution	DIN 43650-A <b>8244</b>
Ausgangssignal Signal de sortie Output	
	2 1
8244.XX.2XXX.XX.19	

<sup>1)</sup> nur mit vorschriftsmässig montierter Kabeldose gültig  
valable seulement avec fiche femelle montée selon instructions  
provided female connector is mounted according to instructions

Ausgangssignal / Signal de sortie / Output signal

Output 4 ... 20 mA	Load (U <sub>supply</sub> -10)/20mA	I <sub>supply</sub> (Incl. Load)	U <sub>Supply</sub> 10 ... 34 V DC	82X4.XX.2XXX.XX.XX.XX... <b>19</b>
-----------------------	--	----------------------------------	---------------------------------------	---------------------------------------

Betriebstemperatur / Température de service / Operating temperature

-25°C ... +85°C

Lagertemperatur / Température de stockage / Storage temperature

-40°C ... +85°C



<b>Bereich</b>	0 ... 1.6	<b>Überdruck</b>	max.	3
<b>Plage</b>	0 ... 2.5	<b>Surpression</b>		6
<b>Range</b>	0 ... 4.0	<b>Over pressure</b>		10
	0 ... 6.0			15
bar	0 ... 10.0	bar		20
	0 ... 16.0			32
	0 ... 25.0			80
	0 ... 40.0			80
	0 ... 60.0			200
	0 ... 100.0			200
	0 ... 160.0			500
	0 ... 250.0			500
	0 ... 400.0			800
	0 ... 600.0			1000

Druckanschluss / Raccord de pression / Pressure connection

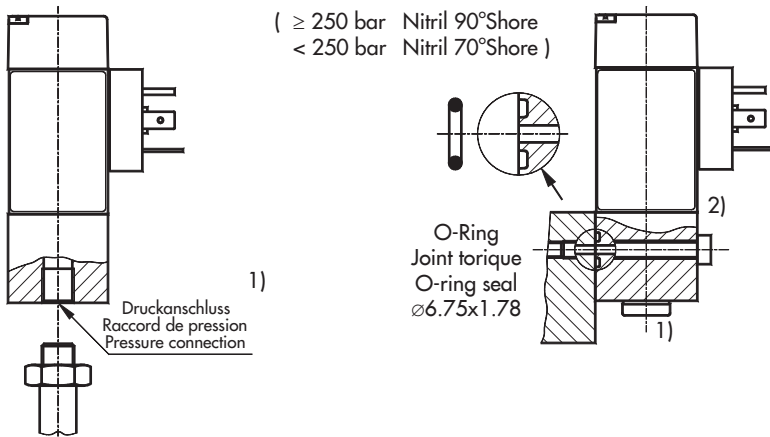

Anziehdrehmoment  
Couple de serrage  
Torque moment  
1) 20.0 Nm  
2) 6.0 Nm  
Festigkeitsklasse  
Classe de résistance 8.8  
Property class

Korrektur von Nullpunkt und Spanne\*  
Ajustage du zéro et sensibilité\* / Adjustment of zero and span\*

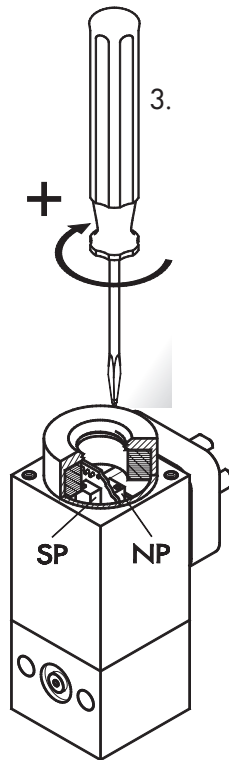
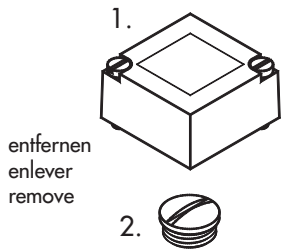

- \* Das Gerät ist werkseitig kalibriert und bedarf keiner weiteren Einstellung.
- \* L'appareil est ajusté à l'usine, un réglage ultérieur n'est pas nécessaire.
- \* The instrument has been factory calibrated, no further adjustment is normally required.

KEINE GARANTIE NACH VERSTELLUNG DER WERKSEITIGEN KALIBRATION.

SANS GARANTIE APRÈS AJUSTAGE DE LA CALIBRATION D'USINE.

NO WARRANTY AFTER ADJUSTEMENT OF FACTORY CALIBRATION.

Achtung / Attention / Attention

