



HAUPTMERKMALE

- ◆ Schutzrohr: für flüssige Medien
- ◆ Anwendung: Thermostat

CARACTÈRES DISTINCTIFS

- ◆ Doigt de gant: pour médias liquides
- ◆ Application: Thermostat

MAIN CHARACTERISTICS

- ◆ Measuring range: for liquide medias
- ◆ Application: Thermostat

**SCHUTZROHRE
FÜR DIREKTE BEFESTIGUNG**

Klemm-Befestigung, seitlich
Raccord pour vis, latérale
Grubscrew lock, lateral

Befestigungsmutter mit Distanzierung (Kühlelement)
Tube de refroidissement et raccord pour vis latérale
Grubscrew locked with thermal distance piece

Material : Messing vernickelt
Matière : Laiton nickelé
Material : Brass nickel plated

für Typ/ pour type/ for type
Ambistat 100 ... 199
Industat 400 ... 419
Ministat 600 ... 619
Laborstat 753 ... 770

12

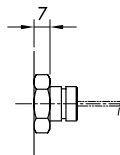

18

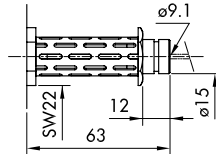

**PROTECTION TUBES FOR
DIRECT MOUNTING**

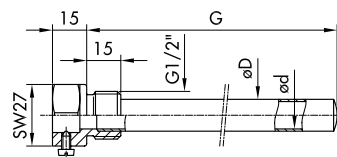

**121X
181X**

Überwurfmutter
Ecrou mobile
Captive nut

Material : Messing vernickelt
Stahl 1.4435/1.4404
Matière : Laiton nickelé
Acier inox 1.4435/1.4404
Material : Brass nickel plated
Stainless steel 1.4435/1.4404

für Typ/ pour type/ for type
Ambistat 100 ... 199
Industat 400 ... 419
Ministat 624 ... 634
Navistat 471, 472

14

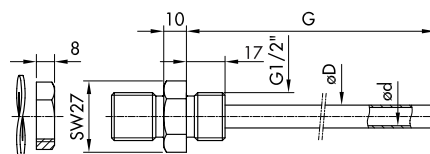
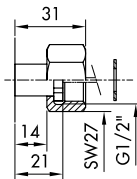

141X

Konsole mit Befestigungsflansch, seitlich
Console avec raccord pour vis, latérale
Console with grubscrew locked, lateral

Material : Messing chem. vernickelt
Matière : Laiton chim. nickelé
Material : Brass chem. nickel plated

für Typ/ pour type/ for type
Duostat300 ... 319

21

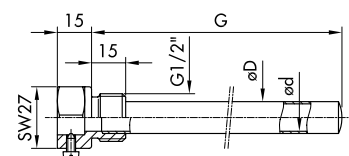
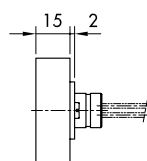

211X

**SCHUTZROHRE
FÜR DIREKTE BEFESTIGUNG**

**DOIGT DE GANT
POUR MONTAGE DIRECT**

**PROTECTION TUBES FOR
DIRECT MOUNTING**

Messing vernickelt
Druckfest bis 25 bar

laiton nickelé Résistance à la pression jusqu'à
25 bar

brass nickel plated
Pressure proof upto 25 bar

Fühler Sonde Sensor	Schutzrohr Doigt de gant Protection tube	[mm]			Länge G [mm]/ Longueur G [mm]/ Length G [mm]												
		D	d	G min.	65	80	90	100	110	150	200	250	300	400	450	500	600
42X 32X 12X	1216/1816	10	8	200							5	9	5	5	9	5	
150								5	5	5	9	5	5	9	5		
110							5	5	5	9	5	5	9	5			
43X 33X 13X	1217/1817	12	10	140						5	9	9	9	9	9	9	
110							5	5	9	9	9	9	9	9			
90					9	9	5	5	9	9	9	9	9	9			
44X 34X 14X	1219	15	13	80		9	9	9	9	9	9	9	9	9	9	9	
65				9	9	9	9	9	9	9	9	9	9	9			
40				9	9	9	9	9	9	9	9	9	9	9			
46X 36X 16X	1218/2118	14	12	180							9	9	9	5	9	9	
150								9	9	9	9	9	5	9	9		
100						9	9	9	9	9	5	9	9	9			
42X 32X 12X	1416	10	8	200							5	5	5	5	9	5	
150								9	5	5	5	5	5	9	5		
110							9	5	5	5	5	5	5	9	5		
43X 33X 13X	1417	12	10	140						9	5	9	9	9	9	9	
110							5	9	5	9	9	9	9	9			
90					9	9	5	9	5	9	9	9	9	9			
44X 34X 14X	1419	15	13	80		9	9	9	9	9	9	9	9	9	9	9	
65				5	9	9	9	9	9	9	9	9	9	9			
40				5	9	9	9	9	9	9	9	9	9	9			

9 Auf Anfrage
Sur demande
On request

5 Lieferfrist ca. 2 Wochen
Délai de livraison approx. 2 semaines
Delivery time approx. 2 weeks

Rostfrei 1.4435/1.4404
Druckfest bis 40 bar

Acier inox 1.4435/1.4404 Résistance à la
pression jusqu'à 40 bar

Stainless steel 1.4435/1.4404
Pressure proof upto 40 bar

Fühler Sonde Sensor	Schutzrohr Doigt de gant Protection tube	[mm]			Länge G [mm]/ Longueur G [mm]/ Length G [mm]												
		D	d	G min.	65	80	90	100	110	150	200	250	300	400	450	500	600
42X 32X 12X	1211/1811	10	8	200							5	9	5	5	9	5	
150								9	5	5	9	5	5	9	5		
110							9	5	5	9	5	5	9	5			
43X 33X 13X	1212/1812	12	10	140						9	9	9	9	9	9	9	
110							9	9	9	9	9	9	9	9			
90					9	9	9	9	9	9	9	9	9	9			
44X 34X 14X	1214	15	13	80		9	9	9	9	9	9	9	9	9	9	9	
65				9	9	9	9	9	9	9	9	9	9	9			
40				9	9	9	9	9	9	9	9	9	9	9			
46X 36X 16X	1213/2113	14	12	180							9	9	9	9	9	9	
150								9	9	9	9	9	9	9			
100						9	9	9	9	9	9	9	9	9			
42X 32X 12X	1411	10	8	200							5	9	9	9	9	9	
150								9	5	5	9	9	9	9	9		
110							9	5	5	9	9	9	9	9	9		
43X 33X 13X	1412	12	10	140						9	9	9	9	9	9	9	
110							5	9	9	9	9	9	9	9			
90					9	9	5	9	9	9	9	9	9	9			
44X 34X 14X	1414	15	13	80		9	9	9	9	9	9	9	9	9	9	9	
65				5	9	9	9	9	9	9	9	9	9	9			
40				5	9	9	9	9	9	9	9	9	9	9			

9 Auf Anfrage
Sur demande
On request

5 Lieferfrist ca. 2 Wochen
Délai de livraison approx. 2 semaines
Delivery time approx. 2 weeks

**SCHUTZROHRE FÜR FREI VERLEGTES
KAPILLARROHR**

**DOIGT DE GANT POUR TUBE CAPIL-
LAIRE À MONTER LIBRE**

**PROTECTION TUBES FOR
REMOTE SENSOR**

**831X
841X**

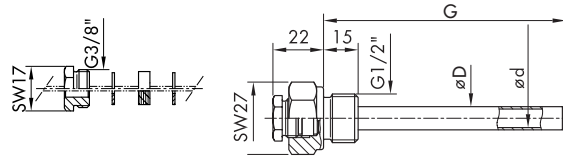
siehe Zubehör/ voir accessoires/ see accessories

Zusätzlich zur Bestellnummer wird die Angabe der Länge **G** [mm] benötigt!

Additional pour la commande est déclarer la longueur **G** [mm]!

In addition to the ordering number please indicate immersion **G** [mm]!

**Messing vernickelt
Druckfest bis 25 bar**

**laiton nickelé Résistance à la pression jusqu'à
25 bar**

**brass nickel plated
Pressure proof upto 25 bar**

Fühler Sonde Sensor	Schutzrohr Doigt de gant Protection tube	[mm]			Länge G [mm]/ Longueur G [mm]/ Length G [mm]												
		D	d	G min.	65	80	90	100	110	150	200	250	300	400	450	500	600
42X 32X 12X	8316	10	8	200 150 110						5 5 5	5 5 5	5 5 5	5 5 5	9 9 9	9 9 9	5	
43X 33X 13X	8317	12	10	140 110 90			9	5	5 5 5	5 5 5	9 9 9	9 9 9	9 9 9	9 9 9	9 9 9	9	
44X 34X 14X	8319	15	13	80 65 40	5	9	9	9	9	9	9	9	9	9	9	9	9
46X 36X 16X	8318	14	12	180 150 100				5	9	5	9	9	5	9	9	9	9

9 Auf Anfrage
Sur demande
On request

**Rostfrei 1.4435/1.4404
Druckfest bis 40 bar**

**Acier inox 1.4435/1.4404 Résistance à la
pression jusqu'à 40 bar**

**Stainless steel 1.4435/1.4404
Pressure proof upto 40 bar**



Fühler Sonde Sensor	Schutzrohr Doigt de gant Protection tube	[mm]			Länge G [mm]/ Longueur G [mm]/ Length G [mm]											
		D	d	G min.	65	80	90	100	110	150	200	250	300	400	450	500
42X 32X 12X	8411	10	8	200 150 110					5	5	5	9	5	5	9	5
43X 33X 13X	8412	12	10	140 110 90			9	9	5	9	9	9	9	9	9	9
44X 34X 14X	8414	15	13	80 65 40	5	9	9	9	9	9	9	9	9	9	9	9
46X 36X 16X	8413	14	12	180 150 100				5	9	5	9	9	5	5	9	9

5 Lieferfrist ca. 2 Wochen
Délai de livraison approx. 2 semaines
Delivery time approx. 2 weeks

FÜHLER

SONDE

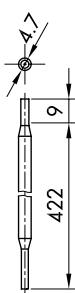
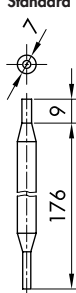
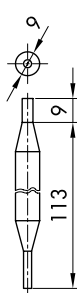
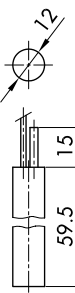
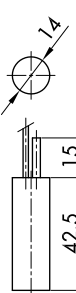
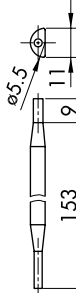
SENSOR

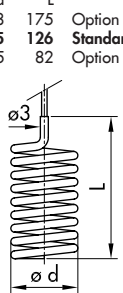
Bereich Plage Range		Standard 						
°C -30 ... +40 -10 ... +25 0 ... 35 10 ... 45 10 ... 80 15 ... 30								d L 18 175 Option 25 126 Standard 35 82 Option
1.4435 (316 L)/1.4404 No.		421		441				481 (nur d=35)
Kupfer /Cuivre / Copper No.	412	422	432	442	452	462	472	482
Kupfer vernickelt Cuivre nickelé Copper nickel plated No.	413	423	433	443	453	463	473	483

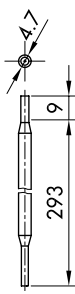
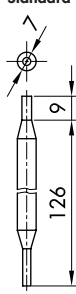
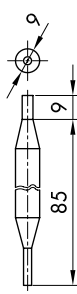
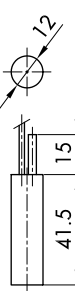
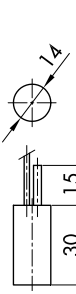
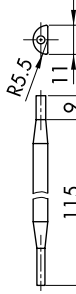
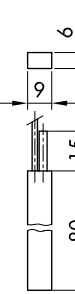
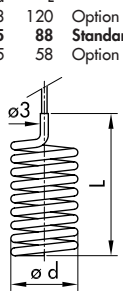
Bereich Plage Range		Standard 						
°C -10 ... +35 -10 ... 80 5 ... 95 20 ... 110 20 ... 150								d L 18 120 Option 25 88 Standard 35 58 Option
1.4435 (316 L)/1.4404 No.	311	321	331	341				381 (nur d=35)
Kupfer /Cuivre / Copper No.	312	322	332	342	352	362	372	382
Kupfer vernickelt Cuivre nickelé Copper nickel plated No.	313	323	333	343	353	363	373	383

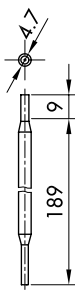
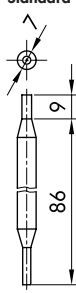
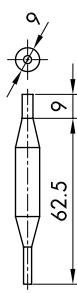
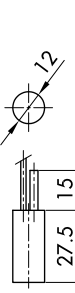
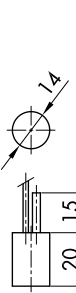
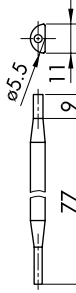
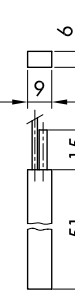
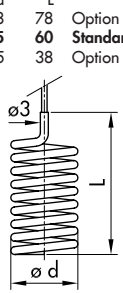
Bereich Plage Range		Standard 						
°C 20 ... 230 40 ... 300 70 ... 350								d L 18 78 Option 25 60 Standard 35 38 Option
1.4435 (316 L)/1.4404 No.	111	121	131	141				181 (nur d=35)
Kupfer /Cuivre / Copper No.	112	122	132	142	152	162	172	182
Kupfer vernickelt Cuivre nickelé Copper nickel plated No.	113	123	133	143	153	163	173	183

ZUBEHÖR

Für frei verlegtes Kapillarrohr

Kapillarrohr-Verschraubung

Auf dem Kapillarrohr verschiebbar, dichtend bis ca. 2 bar, mittels Metall- oder PTFE-Konus.

Anschlussgewinde: G1/8" aussen.

PTFE-Konus bis 280°C	Ms vernickelt	60
Metall-Konus bis 350°C	Ms vernickelt	61
PTFE-Konus bis 280°C		
1.4435 (316 L)/1.4404		62
Metall-Konus bis 350°C		
1.4435 (316 L)/1.4404		63

ACCESSOIRES

Pour tube capillaire à monter libre

Raccord à vis pour tube capillaire

Position ajustable sur tube capillaire, étanche jusqu'à 2 bar, avec cône métal ou PTFE. Filet du raccord: G1/8" mâle

Cône PTFE jusqu'à 280°C	laiton nickelé	60
Cône métal jusqu'à 350°C	laiton nickelé	61
Cône PTFE jusqu'à 280°C		
1.4435 (316 L)/1.4404		62
Cône métal jusqu'à 350°C		
1.4435 (316 L)/1.4404		63

ACCESSORIES

For remote sensor

Capillary double camp nut assembly

Adjustable position on capillary tube, tight upto 2 bar, sealing through metal or PTFE cone.

Connection thread: G1/8" male.

PTFE cone upto 280°C	Brass nickel plat.	60
Metal cone upto 350°C	Brass nickel plat.	61
PTFE cone upto 280°C		
1.4435 (316 L)/1.4404		62
Metal cone upto 350°C		
1.4435 (316 L)/1.4404		63

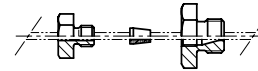
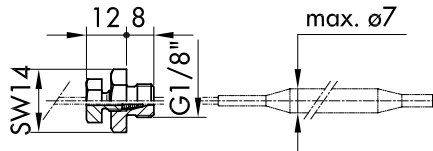

Fühler-Doppelverschraubung

Bis 40 bar dichtender Metallkonus am Fühler. Nicht verschiebbar. Nur für Fühler mit 4,7, 7 und 9 mm Durchmesser.

G1/4" aussen	Ms vernickelt	65
G1/4" aussen	1.4435 (316 L)/1.4404	66
G3/8" aussen	Ms vernickelt	68
G3/8" aussen	1.4435 (316 L)/1.4404	69
G3/8" aussen	Polyamid	70

Raccord double pour sondes

Étanche jusqu'à 40 bar avec cône métal au sonde. Pas ajustable. Seulement pour sondes avec diamètre 4,7, 7 et 9 mm.

G1/4" mâle	laiton nickelé	65
G1/4" mâle	1.4435 (316 L)/1.4404	66
G3/8" mâle	laiton nickelé	68
G3/8" mâle	1.4435 (316 L)/1.4404	69
G3/8" mâle	Polyamid	70

Sensor double threaded coupling nut

Tight upto 40 bar through metal cone on sensor. Not adjustable. Only for sensors with diameter 4,7, 7, and 9 mm.

G1/4" male	Brass nickel plat.	65
G1/4" male	1.4435 (316 L)/1.4404	66
G3/8" male	Brass nickel plat.	68
G3/8" male	1.4435 (316 L)/1.4404	69
G3/8" male	Polyamid	70

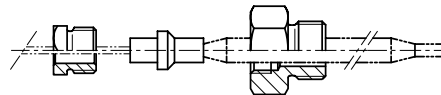
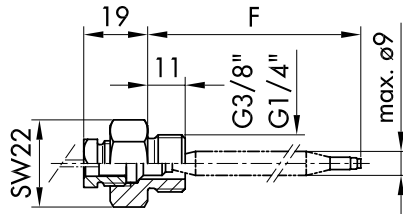

G1/2" aussen	Ms vernickelt	71
G1/2" aussen	1.4435 (316 L)/1.4404	72

G1/2" mâle	laiton nickelé	71
G1/2" mâle	1.4435 (316 L)/1.4404	72

G1/2" male	Brass nickel plat.	71
G1/2" male	1.4435 (316 L)/1.4404	72

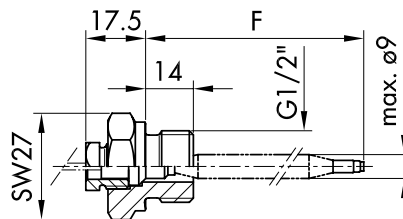

ZUBEHÖR

Für frei verlegtes Kapillarrohr

Kapillarrohr-Durchführung

Verschiebbare Verschraubung, dient zur Fixierung des Kapillarrohres. Gummi ölfest, bis ca. 2 bar dichtend. Maximale Temperatur 200°C (getemperter Silikongummi).

G3/8" aussen	Ms vernickelt	80
G3/8" aussen	1.4435 (316 L)/1.4404	81

ACCESSOIRES

Pour tube capillaire à monter libre

Traverséepour tube capillaire

Raccord ajustable pour fixation de tube capillaire. Gomme (résistant contre huile), étanche jusqu'à approx. 2 bar. Température max. 200°C (gomme silicon vieillis).

G3/8" mâle	laiton nickelé	80
G3/8" mâle	1.4435 (316 L)/1.4404	81

ACCESSORIES

For remote sensor

Capillary locking nut assembly

Adjustable clamping nut for fixation of capillary tube. Rubber oil-proof, tight upto approx. 2 bar, max. temperature 200°C (tempered silicon rubber).

G3/8" male	Brass nickel plat.	80
G3/8" male	1.4435 (316 L)/1.4404	81

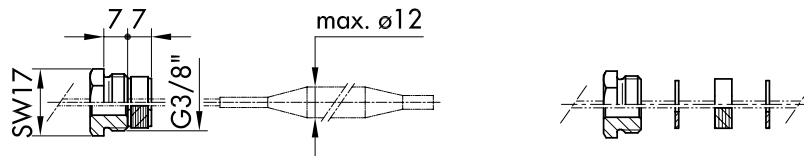

Zubehör zum Schutz des Kapillarrohrs

Metallschlauch	Ms vernickelt	90
Metallschlauch	1.4306 (304 L)/1.4404	91

Accessoires pour protection de tube capillaire

Tuyau de métal	laiton nickelé	90
Tuyau de métal	1.4306 (304 L)/1.4404	91

Accessories for capillary tube protection

flexible metal tube	Brass nickel plat.	90
flexible metal tube	1.4435 (316 L)/1.4404	91

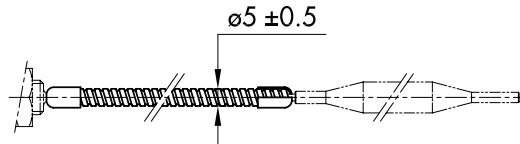

PVC-Schlauch

92 Tuyau PVC

92 PVC tube

92

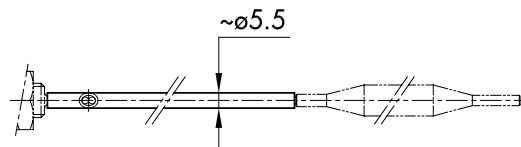
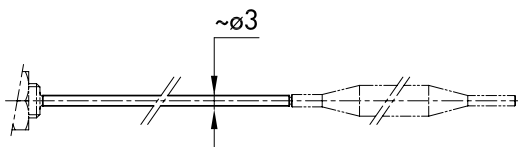

Duostat (2XX), Doppelthermostat (3XX)



Trafag entwickelt und produziert auch speziell auf Ihre Bedürfnisse zugeschnittene Produkte. Bitte fragen Sie uns an.
Trafag développe et fabrique des produits adaptés à vos besoins spécifiques en se basant sur votre cahier des charges. Contactez-nous s.v.p.
Trafag develops and manufactures customized products according to your specifications to meet your requirements. Please contact us.